

# RESCUE EcoTech® Outdoor ECM Condenser Fan, 5.6" and 6.3" Diameter, Totally Enclosed, Air Over (TEAO)

## APPLICATIONS:

High-Efficiency ECM for Condensers

## FEATURES:

### Outdoor 48 Frame ECM, Single Phase

- Line-voltage starting motor with 2 speeds
- Surge protection: 6000V
- 24V speed tap to adjust second speed
- 24V rotation tap to change rotation
- High 60°C max ambient operating temperature
- Shaft-Up or Down mounting

### Outdoor 56 Frame ECM, Three Phase

- Three Phase Commercial Condenser
- Rigid Base Mount
- ECM design provides high efficiency over broad RPM range
- Totally enclosed air-over design with integrated motor control
- Onboard interface board allows easy setup at installation without need for separate programming
- Horizontal or shaft-up mounting
- Active power factor correction
- 0-10Vdc or 10-0Vdc Inputs
- Constant Speed Operation
- NEMA® 56 Frame

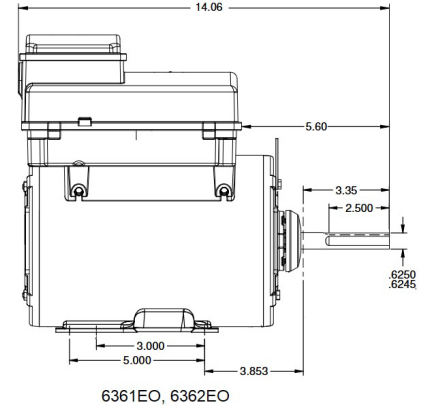
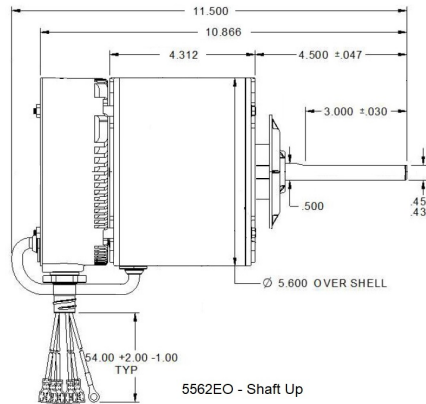
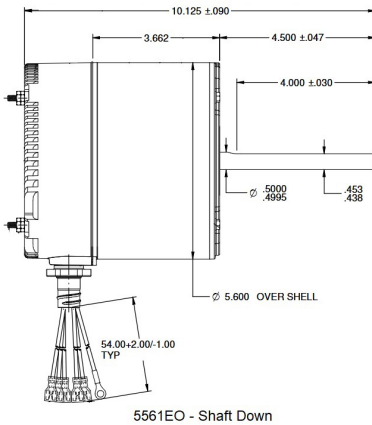
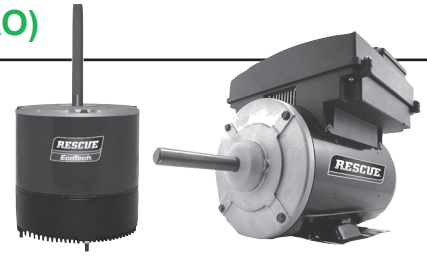

## Outdoor 48 Frame ECM, Single Phase

| HP  | RPM            | Voltage | Catalog Number | List  | Amps | Rotation         | Ship Wt. (lbs) |
|-----|----------------|---------|----------------|-------|------|------------------|----------------|
| 1/3 | 1200 / VAR SPD | 208-230 | 5561EO         | \$352 | 2.5  | CCW LE REV       | 11             |
| 1/3 | 1200 / VAR SPD | 208-230 | 5562EO         | \$352 | 2.5  | CCW LEAD END REV | 10             |

## Outdoor 56 Frame ECM, Three Phase

| HP    | RPM              | Voltage | Catalog Number | List   | Amps    | Rotation   | Ship Wt. (lbs) |
|-------|------------------|---------|----------------|--------|---------|------------|----------------|
| 2 1/4 | 300-1200/VAR SPD | 460     | 6362EO         | \$1650 | 2.7     | REVERSIBLE | 56             |
| 2 1/2 | 300-1200/VAR SPD | 208-230 | 6361EO         | \$1564 | 6.5-5.8 | REVERSIBLE | 45             |

